

High Chamfer Model SC-5

Desk Top Chamferring Machine



Model SC-5



Speed Control SC-5iv

Feature

- Maximum Chamfering Size 5C
- Chamfering fast and sure
- Easy operation
- Cutting chip is hardmetal
- 4 side of square chip can be used
- Cutting chip can be moved to front and back by handle
- The Unit is right so can be carried to the site to be used.
- Can be used as bevelling for welding
- Alminum, Stainless Steel, Plastic are available (Cutting chips are dfferent)
- Speed contro model can be changed cutting speed

Specification

	Standard SC- 5	Speed Cotrol SC- 5 iv
Max. Chamfering Length		
400N/mm ²	5C (Soft Metal)	
600N/mm ²	3C (Stainless Steel)	
Chamfering Angle	15 ~ 45 °	
Cutting Chips Q'ty	Standard 6 (Max. 12)	
Speed	2810rpm/50Hz 3380rpm/60Hz	pprox. 570-5700rpm
Frequency	50Hz/60Hz	10Hz ~ 100Hz
Current	2.1A/50Hz , 1.9A/60Hz	
Power Input	3 phased/200V	
Power Consumptior	0.4kW	
Weight	30kg	32kg

Chamfering Angle

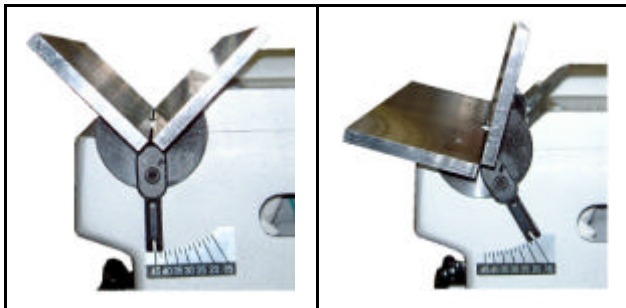

Chamfering Angle 45 °

Chamfering Angle 15 °

Chamfering angle can be adjusted between 15° ~ 45°

Speed Controller



Speed Controller

Dimension

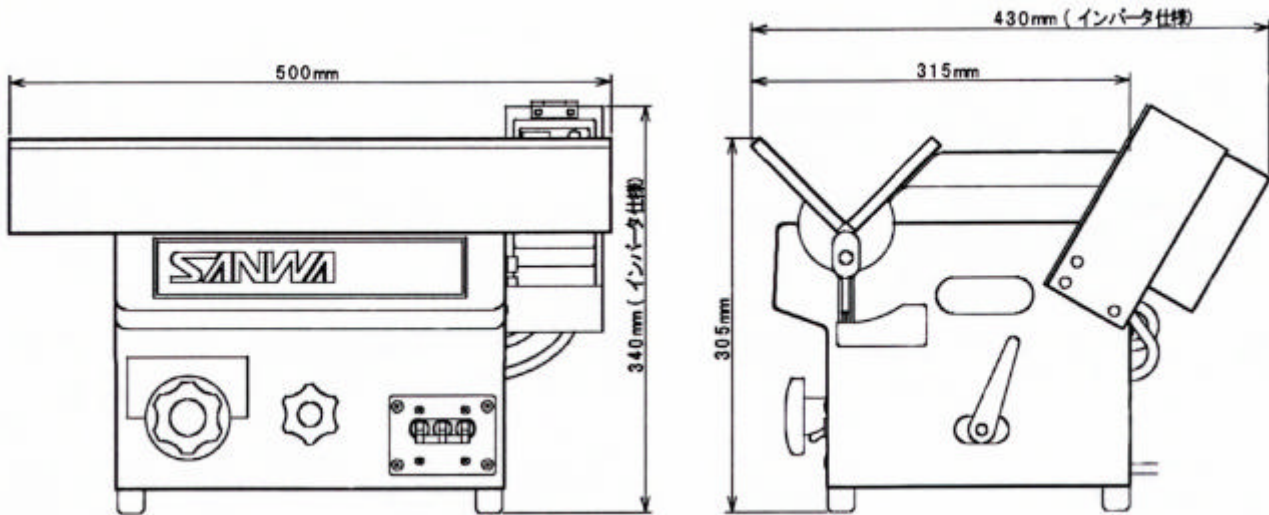

Chamfering Angle Sample

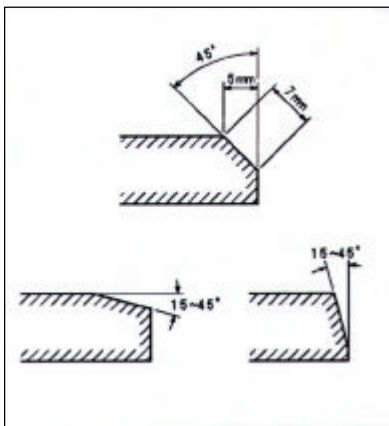

Option

Slide Plate



Feature

- Set it on the Guide Plate
- Scratches on the plastic material will be deduct
- Material is bakelite so smooth sliding with low friction

Sanwa Co., Ltd
 559 Tonogaya, Mizuho-machi, Nishitama-gun, Tokyo Japan
 Tel: 81-42-557-7801, Fax: 81-42-557-7750
 Url : <http://www.sanwa-tool.com>